

SERPAC 182

Electronics Enclosures

NOTES:
1. WHEN MACHINE OR I PLATES MODIFICATIONS ARE REQUIRED, USE THE CENTER OF THE BOX TO DIMENSION.

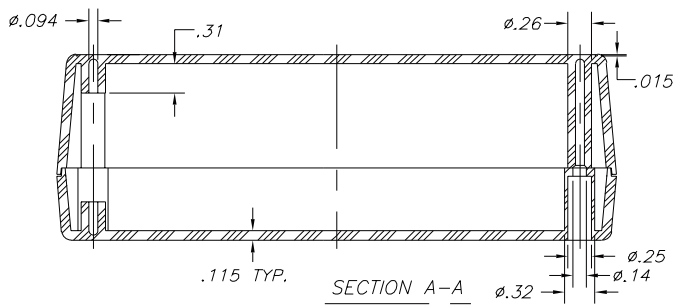
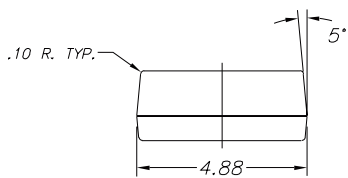
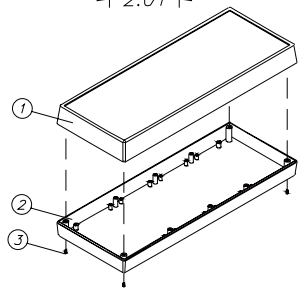
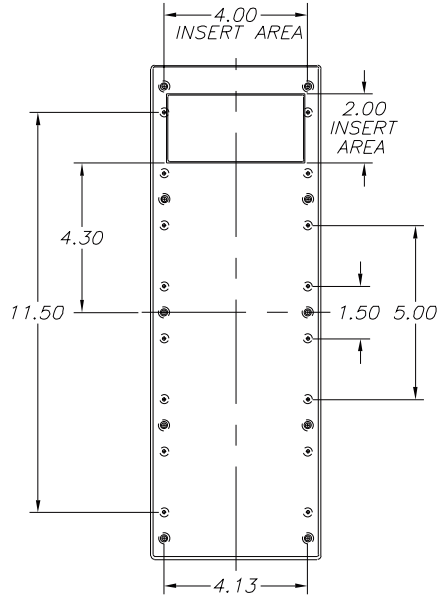
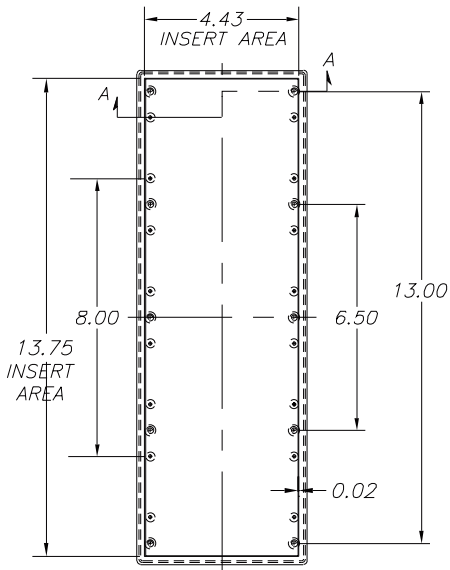
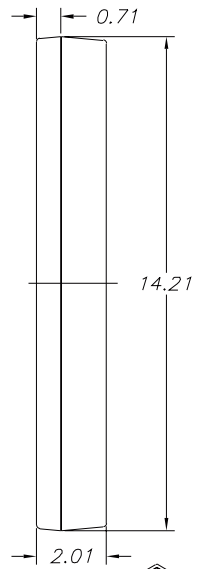

8-17-98. ALL DIMENSIONS ± .010

ITEM	PART NO.	DESCRIPTION	ACCESSORIES	
			PART NO.	DESCRIPTION
1	821	PLASTIC TOP		
2	18	PLASTIC BOTTOM		
3	1025	PLASTIC BATTERY COVER	51	FEET
4	6005	SCREWS (10)		

SERPAC 182-1

Electronics Enclosures

NOTES:
1. WHEN MACHINE OR I PLATES MODIFICATIONS ARE REQUIRED, USE THE CENTER OF THE BOX TO DIMENSION.

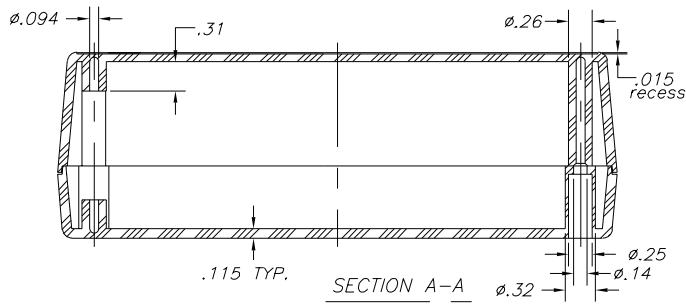
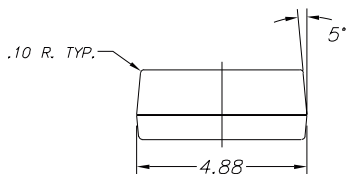
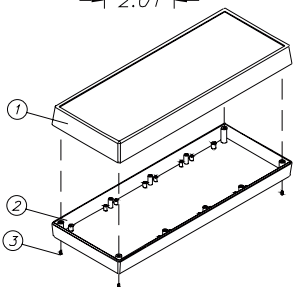
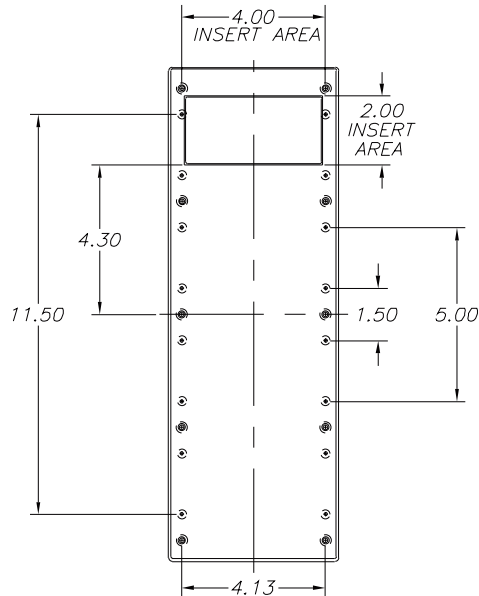
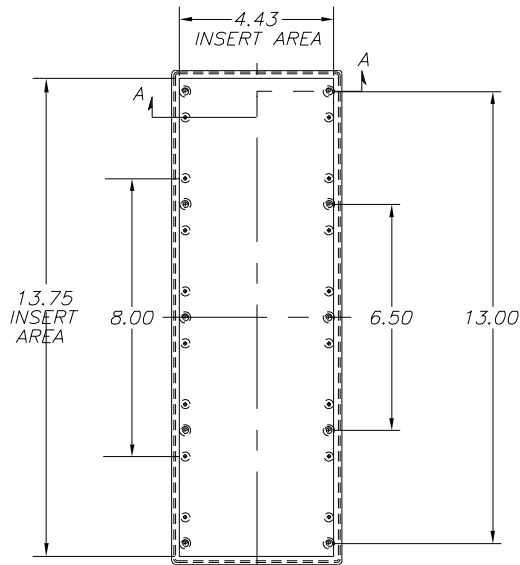
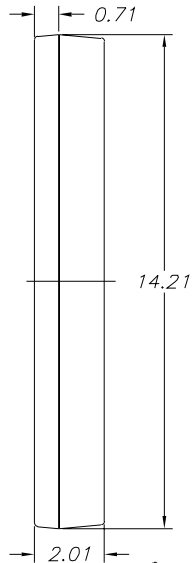

8-17-98.

ALL DIMENSIONS ± .010

ITEM	PART NO.	DESCRIPTION	ACCESSORIES	
			PART NO.	DESCRIPTION
1	821	PLASTIC TOP	51	FEET
2	18	PLASTIC BOTTOM		
3	1025	PLASTIC BATTERY COVER		
4	6005	SCREWS (10)		